

TECHNICAL SPECIFICATION

**Household and similar electrical appliances – Specifying smart capabilities, of
appliances and devices – General aspects**





THIS PUBLICATION IS COPYRIGHT PROTECTED

Copyright © 2017 IEC, Geneva, Switzerland

All rights reserved. Unless otherwise specified, no part of this publication may be reproduced or utilized in any form or by any means, electronic or mechanical, including photocopying and microfilm, without permission in writing from either IEC or IEC's member National Committee in the country of the requester. If you have any questions about IEC copyright or have an enquiry about obtaining additional rights to this publication, please contact the address below or your local IEC member National Committee for further information.

IEC Central Office
3, rue de Varembe
CH-1211 Geneva 20
Switzerland

Tel.: +41 22 919 02 11
Fax: +41 22 919 03 00
info@iec.ch
www.iec.ch

About the IEC

The International Electrotechnical Commission (IEC) is the leading global organization that prepares and publishes International Standards for all electrical, electronic and related technologies.

About IEC publications

The technical content of IEC publications is kept under constant review by the IEC. Please make sure that you have the latest edition, a corrigenda or an amendment might have been published.

IEC Catalogue - webstore.iec.ch/catalogue

The stand-alone application for consulting the entire bibliographical information on IEC International Standards, Technical Specifications, Technical Reports and other documents. Available for PC, Mac OS, Android Tablets and iPad.

IEC publications search - www.iec.ch/searchpub

The advanced search enables to find IEC publications by a variety of criteria (reference number, text, technical committee,...). It also gives information on projects, replaced and withdrawn publications.

IEC Just Published - webstore.iec.ch/justpublished

Stay up to date on all new IEC publications. Just Published details all new publications released. Available online and also once a month by email.

Electropedia - www.electropedia.org

The world's leading online dictionary of electronic and electrical terms containing 20 000 terms and definitions in English and French, with equivalent terms in 16 additional languages. Also known as the International Electrotechnical Vocabulary (IEV) online.

IEC Glossary - std.iec.ch/glossary

65 000 electrotechnical terminology entries in English and French extracted from the Terms and Definitions clause of IEC publications issued since 2002. Some entries have been collected from earlier publications of IEC TC 37, 77, 86 and CISPR.

IEC Customer Service Centre - webstore.iec.ch/csc

If you wish to give us your feedback on this publication or need further assistance, please contact the Customer Service Centre: csc@iec.ch.



TECHNICAL SPECIFICATION

Household and similar electrical appliances – Specifying smart capabilities, of appliances and devices – General aspects

INTERNATIONAL
ELECTROTECHNICAL
COMMISSION

ICS 97.030

ISBN 978-2-8322-4933-8

Warning! Make sure that you obtained this publication from an authorized distributor.

CONTENTS

FOREWORD.....	4
INTRODUCTION.....	6
1 Scope.....	8
2 Normative references	9
3 Terms, definitions and abbreviated terms	9
3.1 Terms and definitions.....	9
3.2 Abbreviated terms.....	15
4 Reference framework	15
4.1 Logical architecture.....	15
4.2 Capabilities of the CEM and the DEM	17
5 Smart operating modes.....	18
5.1 Classification of smart operating modes.....	18
5.2 Smart operating modes for specific devices	19
5.2.1 General	19
5.2.2 Safety.....	20
5.2.3 Always available functions.....	20
5.2.4 Initiation and termination of smart operation	20
5.2.5 Interaction with the CEM.....	21
5.2.6 Smart devices in user operation.....	21
5.3 Operation in "constrain or reduce load" mode	21
5.3.1 General	21
5.3.2 Fixed reference value	22
5.3.3 Floating reference value	22
5.3.4 Exclusion of specified functions	22
5.3.5 Multiple criteria.....	22
5.3.6 Preset constraint levels	22
5.3.7 Variable constraint levels.....	22
5.3.8 Expressing constraints in power or energy terms	23
5.4 Operation in "start or increase load" mode	23
5.4.1 General	23
5.4.2 Suitable devices	23
5.4.3 Protections and safety measures	24
5.4.4 Devices already under load	24
5.4.5 Risk of energy waste	24
5.5 Operation in "defer cycle" mode.....	24
5.5.1 Smart deferment and user deferment.....	24
5.5.2 Information required for this mode	25
5.6 Operation in "start or increase supply" mode.....	25
5.6.1 General	25
5.6.2 Suitable products and devices	25
5.6.3 Protections and safety measures	25
5.6.4 SSESs already supplying energy	26
5.7 Operation in "no supply" mode.....	26
5.8 Overrides.....	26
5.9 Device information transmission	27
5.10 Status Indicators.....	27

6	Testing smart operating modes	27
6.1	General principles	27
6.2	Setup for tests	28
6.3	Determining compliance with standards for smart performance	29
6.4	Determining the impact of smart operation on device performance	29
7	Information to be provided by manufacturers	30
7.1	General	30
7.2	Information that could to be provided	30
7.2.1	Technical information in device-performance standards	30
7.2.2	Information for device users	31
7.2.3	Information for appliance installers	31
Annex A (informative)	Device performance standards for typical devices	32
Annex B (informative)	Example of response rules for smart operating modes	33
Bibliography		35
Figure 1	– Logical Architecture	16
Figure 2	– Possible CEM, DEM and device configurations	16
Table 1	– Capabilities of customer (energy) manager and device (energy) manager	18
Table 2	– Smart operating modes	19
Table A.1	– Devices within scope of IEC TC59 and its sub-committees	32
Table B.1	–Combinations of smart operating modes, timing and duration	33

INTERNATIONAL ELECTROTECHNICAL COMMISSION

HOUSEHOLD AND SIMILAR ELECTRICAL APPLIANCES – SPECIFYING SMART CAPABILITIES, OF APPLIANCES AND DEVICES– GENERAL ASPECTS

FOREWORD

- 1) The International Electrotechnical Commission (IEC) is a worldwide organization for standardization comprising all national electrotechnical committees (IEC National Committees). The object of IEC is to promote international co-operation on all questions concerning standardization in the electrical and electronic fields. To this end and in addition to other activities, IEC publishes International Standards, Technical Specifications, Technical Reports, Publicly Available Specifications (PAS) and Guides (hereafter referred to as "IEC Publication(s)"). Their preparation is entrusted to technical committees; any IEC National Committee interested in the subject dealt with may participate in this preparatory work. International, governmental and non-governmental organizations liaising with the IEC also participate in this preparation. IEC collaborates closely with the International Organization for Standardization (ISO) in accordance with conditions determined by agreement between the two organizations.
- 2) The formal decisions or agreements of IEC on technical matters express, as nearly as possible, an international consensus of opinion on the relevant subjects since each technical committee has representation from all interested IEC National Committees.
- 3) IEC Publications have the form of recommendations for international use and are accepted by IEC National Committees in that sense. While all reasonable efforts are made to ensure that the technical content of IEC Publications is accurate, IEC cannot be held responsible for the way in which they are used or for any misinterpretation by any end user.
- 4) In order to promote international uniformity, IEC National Committees undertake to apply IEC Publications transparently to the maximum extent possible in their national and regional publications. Any divergence between any IEC Publication and the corresponding national or regional publication shall be clearly indicated in the latter.
- 5) IEC itself does not provide any attestation of conformity. Independent certification bodies provide conformity assessment services and, in some areas, access to IEC marks of conformity. IEC is not responsible for any services carried out by independent certification bodies.
- 6) All users should ensure that they have the latest edition of this publication.
- 7) No liability shall attach to IEC or its directors, employees, servants or agents including individual experts and members of its technical committees and IEC National Committees for any personal injury, property damage or other damage of any nature whatsoever, whether direct or indirect, or for costs (including legal fees) and expenses arising out of the publication, use of, or reliance upon, this IEC Publication or any other IEC Publications.
- 8) Attention is drawn to the Normative references cited in this publication. Use of the referenced publications is indispensable for the correct application of this publication.
- 9) Attention is drawn to the possibility that some of the elements of this IEC Publication may be the subject of patent rights. IEC shall not be held responsible for identifying any or all such patent rights.

The main task of IEC technical committees is to prepare International Standards. In exceptional circumstances, a technical committee may propose the publication of a technical specification when

- the required support cannot be obtained for the publication of an International Standard, despite repeated efforts, or
- the subject is still under technical development or where, for any other reason, there is the future but no immediate possibility of an agreement on an International Standard.

Technical specifications are subject to review within three years of publication to decide whether they can be transformed into International Standards.

IEC TS 62950, which is a technical specification, has been prepared by Working Group 15: Connection of household appliances to smart grids and appliances interaction, of IEC technical committee 59: Performance of household and similar electrical appliances.

The text of this technical specification is based on the following documents:

Enquiry draft	Report on voting
59/666/DTS	59/673/RVDTS

Full information on the voting for the approval of this technical specification can be found in the report on voting indicated in the above table.

This document has been drafted in accordance with the ISO/IEC Directives, Part 2.

The committee has decided that the contents of this document will remain unchanged until the stability date indicated on the IEC website under "<http://webstore.iec.ch>" in the data related to the specific document. At this date, the document will be

- reconfirmed,
- withdrawn,
- replaced by a revised edition, or
- amended.

A bilingual version of this publication may be issued at a later date.

INTRODUCTION

Technologies related to "smart grids" have been emerging for some time, for a range of reasons, including the need to reduce greenhouse gas emissions, utilise renewable energy resources and increase the overall resilience and efficiency of the electricity supply system as a whole. The electricity usage of the residential sector, especially household appliances, is a significant contributor to total energy consumption and peak demand. At the same time, consumers expect that innovations in the field of information technology will enhance user experiences in the context of "smart" home systems and "smart" appliances.

IEC TC 59 has considered the needs of the appliance market from a technology point of view and has identified products that will benefit from the potential for state-of-the-art technologies to add smart capabilities to household appliances, different architectures that may give rise to smart capabilities at a system-wide level, and the available protocols to control smart capabilities in household appliances and other devices.

This Technical Specification is intended to develop:

- a common architecture to apply to different use cases and to a wide range of appliance and product types, both inside and outside the scope of IEC TC59 (in this document where the term 'device' is used, it covers both appliances and products outside the scope of TC59); and
- the principles of defining and measuring smart operating modes and performance within the context of the common architecture.

The use cases considered in this document relate to the consumption (and possible discharge to the grid) of electrical energy, but future revisions of this document may not be limited to these aspects.

Appliances that are capable of exchanging information with each other, with the electricity grid and with other agents, and capable of altering their behaviour because of those interactions, are sometimes called "smart appliances". While it is not the task of this Technical Specification to define what constitutes a "smart appliance" in all circumstances, it is however possible to describe and test specific capabilities and modes of operation. Therefore, in this document, the term "smart" is used in conjunction with other terms (as in "smart appliance") in a limited sense, to describe an appliance or other product with the specific capabilities described.

A major driver for building-in such capabilities is to increase the overall resilience and economic efficiency of the electricity supply system as a whole, and its ability to accommodate more variable and distributed sources of generation (especially renewables).¹

There are several possible approaches to describing smart capabilities and smart operation:

- 1) in relation to an absolute indicator (e.g. if an appliance can pass a series of tests it may be described as "smart") – this is analogous to meeting a minimum energy performance standard;
- 2) on a comparative scale (e.g. one appliance may be "smarter" than another) – this is more difficult to demonstrate because it may require essentially subjective judgements of the relative importance of different criteria and different smart operating modes;
- 3) in terms of the trade-offs between smart capabilities and other performance criteria (e.g. an increase in energy consumption or reduction in wash performance that may occur as a result of smart operation).

¹ It is expected that consumers will receive a share of the economic benefits created by smart appliances, but it is not the role of standards to anticipate or limit the business arrangements that might transfer such benefit to the consumer (e.g. tariff structures or cash incentive payments).

These approaches are beyond the scope of this document.

The goal of this document is to support the development of a global market for appliances with smart capabilities by:

- defining the terms associated with smart capabilities and smart operation so that appliances and devices might be described in their specific performance standards as having 'smart capabilities in accordance with IEC standard NNNNN';
- clarifying the points where information is exchanged between smart appliances and devices and the electricity grid;
- defining the smart operating modes of appliances and devices in response to specific conditions;
- describing the general conditions for testing the smart operating modes of appliances and devices; and
- supporting sub-committees within TC59, and other technical committees and standardisation bodies, to include in their product specific performance standards descriptions of relevant smart capabilities and procedures for testing them and for measuring how other aspects of appliance performance might be affected by smart operation.

This document is also intended to assist manufacturers of home energy management systems, customer energy managers and similar products, and energy utilities and other remote agents wishing to encourage user response to variable energy prices or supply situations or wishing to offer direct load control services.

Some products may be capable of responses that are rapid enough to offer frequency and voltage management services to the grid. This is not the main scope of the smart operating modes described in this document, but manufacturers are free to offer such capabilities.

As smart operation usually depends on the integration of the appliance into a larger system, issues of inter-connection and inter-operability are likely to arise. Therefore, the overall 'architecture' of the system (as defined in this document and by other standards) will need to be considered. Any departures from standard architecture should be avoided.

Since the products covered by this document are likely to be widely traded, the inclusion of smart capabilities and operating modes in specific appliance and device performance standards should be flexible with regard to the presence of other equipment (e.g. "smart metering") or specific communication pathways and protocols, as these may not be present at all locations where the product will ultimately be purchased and installed.

It is recognised that the definition and standardisation of smart capabilities is at an early stage of development, and other approaches will emerge. Standardisation bodies and technical committees are urged to document the reasons for adopting alternative or modified approaches, so that they may be taken into account in future revisions of this document.

HOUSEHOLD AND SIMILAR ELECTRICAL APPLIANCES – SPECIFYING SMART CAPABILITIES, OF APPLIANCES AND DEVICES – GENERAL ASPECTS

1 Scope

This Technical Specification (TS) sets out a reference framework for defining and testing smart capabilities and smart operating modes of appliances, small scale energy supplies (SSESs) and other devices (ODs) (collectively termed 'smart devices' if they have the defined capabilities). This document does not set minimum requirements for appliances, SSESs or ODs.

This document focuses on electricity consumption but the principles and general architecture can be applied to other types of energy and other services. This document focuses on appliances, SSESs and ODs, but the principles and general architecture can also be applied to other products that are capable of being equipped with a device (energy) manager (DEM).

This document:

- 1) defines terms that describe the smart capabilities and smart operating modes of appliances, SSESs and ODs;
- 2) describes the way in which such products respond to certain standard instructions and conditions that are likely to arise in the operation of smart grids;
- 3) describes various approaches to measuring how the products respond in particular smart operating modes.

Although many examples are given in relation to particular product types, this document is not intended to fully describe these matters for any particular product type. This document is intended for use by IEC and other standardisation bodies who wish to address smart capabilities and smart operating modes in the performance standards for the products for which they are responsible.

The smart device architecture and configurations described in this document, as illustrated in Figure 1 and Figure 2, are intended to guide but not necessarily limit the architecture for each specific product.

This document is relevant to testing interactions between the customer energy manager (CEM) and the device energy manager (DEM) in configurations 1 and 2, insofar as they are relevant to determining the smart operation of a device. It does not cover the interactions between the DEM and a separate DEM-ready device (in configurations 2 and 3). For the time being, these interactions may be the subject of separate standards.

This document does not cover configuration 4, in which the CEM-DEM interaction cannot be externally manipulated or observed in testing. In configuration 4, only the response of the product as a whole to grid information or remote agent instructions can be tested. This is beyond the scope of this document for the time being.

NOTE: Communications methods and protocols are not within the scope of this document, but their consideration can be useful when applying this document in the development of specific product performance standards. The methods of communication are expected to be either left open, or limited to one or more existing methods and protocols, and be capable of supporting the configurations in Figure 1 and Figure 2, and the capabilities and smart operating modes in Table 1 and Table 2.

2 Normative references

There are no normative references in this document.

3 Terms, definitions and abbreviated terms

3.1 Terms and definitions

For the purposes of this document, the following terms and definitions apply.

ISO and IEC maintain terminological databases for use in standardization at the following addresses:

- IEC Electropedia: available at <http://www.electropedia.org/>
- ISO Online browsing platform: available at <http://www.iso.org/obp>

3.1.1

activation

completion of connections, communications pathways and/or settings necessary to enable smart operation

3.1.2

appliance

electrical apparatus intended for household or similar use

EXAMPLE Refrigerators, dishwashers, clothes washers, clothes dryers, air conditioners, water heaters, circulation pumps, etc.

Note 1 to entry: An appliance can only act as a load.

3.1.3

automatic override

termination or prevention of a period of smart operation, that is not initiated by the user or by a remote agent

3.1.4

constrain or reduce load

operation in which a smart device constrains or reduces its load while still performing its primary function

EXAMPLE 1 An air conditioner that continues to cool while limiting its electrical power to half its rated capacity.

EXAMPLE 2 A fridge freezer that defers defrost and ice-making, while continuing to maintain storage temperature within safe limits.

Note 1 to entry: The constraint or reduction can be achieved by limiting operating power, avoiding or delaying energy-intensive functions that are ancillary to the main function or by other means.

3.1.5

customer energy manager

CEM

component or set of functions with the capability to:

- 1) receive and process grid information, device information and user instructions, and
- 2) manage one or more smart devices.

Note 1 to entry: A CEM can be integrated with a smart device, or can be physically separate.

Note 2 to entry: A CEM manages the energy-using behaviour of a smart device. There can be other managers for other aspects of device behaviour.

Note 3 to entry: While the CEM requirements are outside the scope of this document, IEC 62746-2 provides examples.

3.1.6 defer cycle

operation in which a smart device brings forward or delays a cycle or function compared with the timing that would have occurred under user operation

Note 1 to entry: Defer cycle operation is considered "smart" if it occurs as a result of information transmitted via a CEM or DEM or if it involves trigger criteria programmed into a CEM or DEM. A deferment where the user programs an unconditional delayed start using the controls is not a smart defer cycle mode within the meaning of this document.

3.1.7 device

appliance, small scale energy supply (SSES) or other device (OD)

Note 1 to entry: A device can consist of more than one physical element.

3.1.8 DEM-ready device

device that is capable of being equipped with a DEM

3.1.9 device energy manager DEM

component or set of functions with the capability to:

- 1) receive and process information from a CEM;
- 2) manage one appliance, SSES or other device.

Note 1 to entry: A DEM can be integrated with a CEM and/or a device or be physically separate.

Note 2 to entry: A DEM manages the energy-using behaviour of a device. There can be other managers for other aspects of device behaviour.

3.1.10 device information

information received by a CEM directly from or relating to a device

Note 1 to entry: Such information can include (but is not restricted to) the following categories:

- status (e.g. whether an appliance or OD is on or off; whether an appliance is heating, spinning etc.; whether an SSES is fully charged or generating electricity);
- electricity load (kW) or energy used over a specified period (e.g. kWh per 30 min);
- expected end time of current operating cycle or expected/programmed start/end time of the next cycle;
- expected power profile of the programme selected by the user.

3.1.11 device information transmission

operation in which a smart device communicates device information from the DEM to the CEM

Note 1 to entry: This mode can be a permanent operating mode, and can coexist with other smart operating modes.

3.1.12 device performance standard

standard that covers the performance of a device under user operation and/or under smart operation

Note 1 to entry: A device performance standard that covers smart operation can set rules for defining and testing smart operating modes for that device, and can include methods for comparing the performance of the device in smart operation with performance in user operation.

3.1.13 direct load control operation

operation in which a remote agent is able to initiate smart operation

Note 1 to entry: It is expected that the user would enter into a prior contract with a remote agent, and agree conditions and limitations on direct load control.

**3.1.14
emergency off**

operation in which the smart device enters off/standby mode, and which cannot be over-ridden by the user

Note 1 to entry: While in emergency off mode, the smart device should remain capable of receiving and acting on instructions from the CEM to resume user operation.

Note 2 to entry: Emergency off mode is intended for situations of major difficulty with the grid or with local electricity supply to the premises.

**3.1.15
energy management gateway
EMG**

access point for sending and receiving information and commands between a remote agent or other entity and a CEM

**3.1.16
grid information**

information received by a CEM directly from or relating to the electricity grid

Note 1 to entry: Such information can include (but is not restricted to) the following categories:

- current and future energy prices;
- current and future network constraints;
- emissions-intensity of electricity supply;
- level of renewable energy generation;
- requests or instructions for load modification;
- directly sensed information (e.g. frequency and voltage).

**3.1.17
modular smart device**

combination of a DEM-ready device and a DEM in which the DEM may be physically removed

**3.1.18
no supply**

operation in which a smart SSES does not supply energy to the grid even though user settings call for such operation.

Note 1 to entry: No supply operation can be required during periods of electricity network congestion or for the safety of those working on the network.

**3.1.19
off/standby**

operation in which the smart device minimises its electricity load, while still remaining capable of receiving instructions from the CEM, the user or a remote agent

Note 1 to entry: While in off/standby mode, the smart device does not perform its primary function (e.g. heating, cooling, washing, pumping) but its control circuits may remain energised.

Note 2 to entry: This mode may also be called networked standby.

**3.1.20
one-way communications**

arrangement where data and instructions can flow in one direction only

EXAMPLE From the remote agent to the CEM, and from the CEM to the smart device.

**3.1.21
other device
OD**

product intended for household or similar use that is not an appliance or an SSES

EXAMPLE Other devices can be non-energy (e.g. valves to control the flow of water) or can use forms of energy other than electricity (e.g. natural gas and LPG-using products, with or without electrical connections).

**3.1.22
performance**

performance of a device under user operation and/or under smart operation, as defined in the applicable device performance standard

Note 1 to entry: Performance is defined in different metrics for different product types. Metrics can include:

- energy consumption over a given time period or operating cycle;
- temperatures maintained within storage compartments;
- cleanliness and dryness of wash loads at end of a cycle;
- noise levels.

**3.1.23
power profile**

expected variation in power or energy consumption over the duration of an operating cycle

EXAMPLE Power profile can be expressed as energy used during each operation (e.g. kWh during water heating phase, kWh during main wash, kWh during rinse), as peak power achieved during each operation, etc.

**3.1.24
product**

manufactured item that is usually packaged and offered for sale as a single unit

**3.1.25
reference value**

value used as the starting point for calculating whether a smart device performs as claimed in constrain or reduce load response

EXAMPLE Electrical load at full rated output, average power recorded in the 5-min period immediately preceding the receipt of an instruction or the achievement of trigger criteria.

**3.1.26
remote agent**

entity other than the user that is capable of communicating with a CEM or a smart device

**3.1.27
remote agent instructions**

commands, instructions and preferences transmitted by a remote agent to a CEM, with the aim of modifying the operation of one or more smart devices

Note 1 to entry: Remote agent instructions may aim to modify operation by altering control settings (e.g. switching an appliance to half load) by programming trigger criteria (e.g. "stop operating when energy price exceeds this threshold") or other means.

Note 2 to entry: Remote agent instructions would normally be issued and received in the context of a direct load control contract between the remote agent and the user.

Note 3 to entry: The method of transmission of the instructions is outside the scope of this document.

3.1.28**SSES****small scale energy supply**

product intended for household or similar use that is capable of discharging energy to the grid

EXAMPLE Rooftop photovoltaic systems, residential combined heat and power systems, stationary storage batteries and electric vehicle charge/discharge controllers.

Note 1 to entry: SSESs include storage devices that are also able to act as a load.

3.1.29**smart appliance**

appliance that:

- 1) incorporates or has been equipped with a DEM; and
- 2) is capable of smart operation.

Note 1 to entry: This definition is required for consistency with the logical architecture illustrated in Figure 1 and Figure 2. It is consistent with the definition of a "smart appliance" in IEC/ISO 15067-3:2012. The relevant definition is: "Smart Appliance: home appliance that exchanges command and control data with other units on a home area network". The presence of a DEM is taken to signify the presence of such a capability.

Note 2 to entry: This document uses the term "smart appliance" in a limited sense, to describe an appliance with the specific smart capabilities and modes of operation described in this document. It does not define the number or level of smart capabilities required for an appliance to be considered "smart" in a general sense.

3.1.30**smart device**

smart appliance, smart small-scale energy supply (SSES) or smart other device (OD)

3.1.31**smart operation**

operation in a smart operating mode

SEE Table 2

Note 1 to entry: Smart operation may be initiated by a CEM, a DEM or an authorised remote agent.

Note 2 to entry: User operation, whether direct or remote, is not smart operation.

Note 3 to entry: The trigger criteria for smart operation may be set by the user, the CEM the DEM or an authorised Remote Agent.

3.1.32**smart other device**

another device (not an appliance or an SSES) that:

- 1) incorporates or has been equipped with a DEM; and
- 2) is capable of smart operation.

Note 1 to entry: This document uses the term "smart other device" in a limited sense, to describe another device with the specific smart capabilities and modes of operation described in this document. It does not define the number or level of smart capabilities required for another device to be considered 'smart' in a general sense.

3.1.33**smart performance**

performance of a device under smart operation, as defined in the applicable device performance standard

Note 1 to entry: For a given product type, the same metrics should be measurable under both user performance and smart performance, so that the impact of smart performance can be determined.

3.1.34
smart small-scale energy system
small scale energy system that:

- 1) incorporates or has been equipped with a DEM; and
- 2) is capable of smart operation

Note 1 to entry: This document uses the term "smart SSES" in a limited sense, to describe an SSES with the specific smart capabilities and modes of operation described in this document. It does not define the number or level of smart capabilities required for an SSES to be considered "smart" in a general sense.

3.1.35
start or increase load

operation in which a smart device commences operation, or increases its load if already operating, even though user settings do not call for such operation

3.1.36
start or increase supply

operation in which a smart SSES commences or increases the supply of energy to the grid, even though direct user settings, thermostats or timers do not call for such operation

3.1.37
target value

power or energy consumption that a smart device shall not exceed during constrain or reduce load operation.

EXAMPLE 50 % of electrical load at full output, or 0,5 kWh per 30 min, or an absolute limit of 1,0 kW.

3.1.38
trigger criteria

set of conditions which, when satisfied, causes a device to change its mode of operation

EXAMPLE Trigger criteria may include energy price levels, internal temperatures, presence or absence of occupants etc.

3.1.39
two-way communications

arrangement where data and instructions can flow in both directions

3.1.40
user instructions

commands, instructions and preferences given by a user to a device, to a DEM or to a CEM

EXAMPLE User instructions may be given via control settings (e.g. by pressing "start"), via time programming (e.g. "start operating at 20:00") or via programming trigger criteria (e.g. "start operating when energy price falls below this threshold").

3.1.41
user operation

operation under user instructions, as distinct from smart operation

Note 1 to entry: A smart device should default to user operation if the DEM is inactive or removed.

3.1.42
user over-ride

termination or prevention of a period of smart operation, that is initiated by the user

3.1.43
smart grid connection point
SGCP

physical and logical interface between the electricity network and the electricity market and the user, with regard to electricity generation, demand and storage

3.2 Abbreviated terms

CEM	customer energy manager
DEM	device energy manager
EMG	energy management gateway
EV	electric vehicle
OD	other device
SGCP	smart grid connection point
SM	smart meter
SSES	small scale energy supply
SC	sub-committee
TC	technical committee
TS	technical specification

4 Reference framework

4.1 Logical architecture

This subclause describes the smart device logical architecture.

The logical architecture is depicted in Figure 1 as logical building blocks. The smart grid connection point (SGCP) represents the interface between the grid and the premises where smart devices are installed.

The energy management gateway (EMG) is an optional component, with the function of translating instructions or commands, but not otherwise processing or interpreting them. Processing occurs in the customer energy manager (CEM), which interacts with one or more smart devices.

A smart device consists of an appliance, small-scale energy system or other device that is equipped with a device energy manager (DEM). The DEM may be integral to the device (i.e. cannot be separated from it) or modular (connected to the device, hence making it a modular smart device).

Figure 2 illustrates the four possible physical configurations of smart devices that fit within the logical architecture.

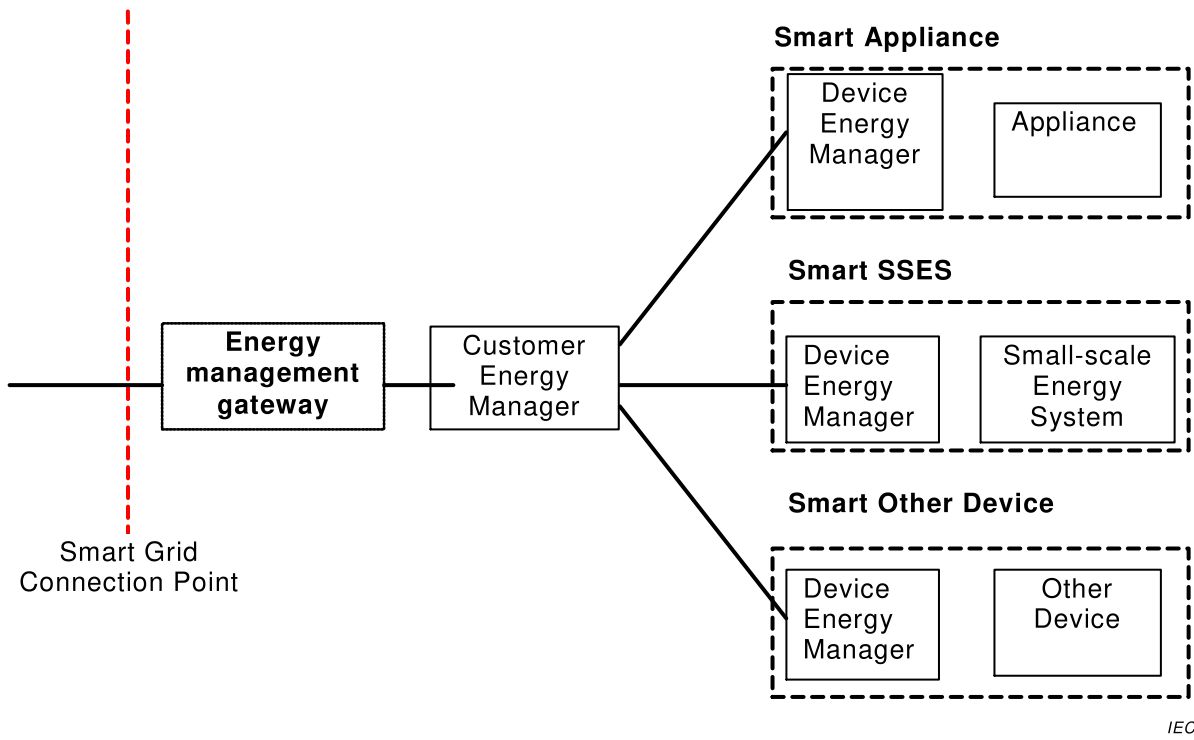

NOTE Logical architecture is adapted from IEC 62746-2.

IEC

Figure 1 – Logical Architecture

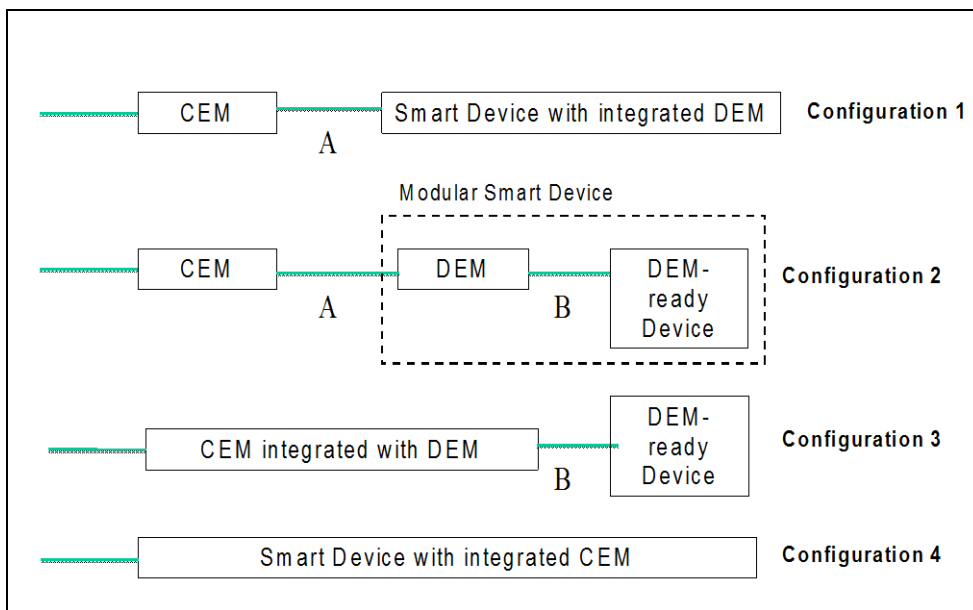

IEC

Key

A: interaction relevant to this document

B: interaction to be covered by separate standards

Figure 2 – Possible CEM, DEM and device configurations

This technical specification is relevant to testing interactions between the CEM and the DEM in configurations 1 and 2, insofar as they are relevant to determining the smart operation of a device. It does not cover the interactions between the DEM and a separate DEM-ready device (in configurations 2 and 3). For the time being, these interactions may be the subject of separate standards, including national standards². Authors of such standards are urged to refer to IEC TR 62746-2.

CEMs and DEMs may be distinct physical devices, functions residing in elements of the smart grid (e.g. smart meters), or functions residing in other devices or products. They may be combined into one product (e.g. configuration 4 in Figure 2).³

This document does not cover configuration 4, in which the CEM-DEM interaction cannot be externally manipulated or observed in testing. In configuration 4, only the response of the product as a whole to grid information or remote agent instructions can be tested.

4.2 Capabilities of the CEM and the DEM

Table 1 lists the capabilities and functions required of CEMs and DEMs. Note that some capabilities are prohibited in either CEMs or DEMs because they are distinguishing features that define the other.

In principle:

- a DEM shall not interact directly with the SGCP – all interactions shall be moderated by a CEM (except for direct sensing of grid voltage and frequency);
- each DEM shall manage/control only one device;
- a CEM may control more than one DEM or smart device.

² A concept with some characteristics of a DEM is under development as ISO/IEC 10192-3, *Modular communications interface for energy management, based on ANSI/CEA-2045 Modular communications interface for energy management*. Users of this document should also make inquiries to IEC TC57 with regard to forthcoming standards that may be relevant.

³ AS/NZS 4755.1 *Framework for demand response capabilities and requirements for demand response enabling devices (DREDs)* defines a device which is a combined CDM and DEM.

Table 1 – Capabilities of customer (energy) manager and device (energy) manager

Capability or function	CEM	DEM
A. Ability to receive grid Information and pass it on to a single device	M	P from/to remote agent ^d M in from CEM
B. Ability to receive grid Information and pass it on to multiple devices	O	NA (can control only one device)
C. Ability to receive, pass on or act on information from a CEM	NA	M ^e
D. Ability to transmit information to a CEM	NA	O
E. Ability to receive information from DEM (including appliance information if available) ^a	M	NA
F. Ability to transmit information to a remote agent.	M	P
G. Ability to receive, pass on or act on emergency off signals	M	M
H. Ability to receive, pass on, or act on signals for other smart operating modes	M	O ^b
I. Ability to receive information from sources other than the DEM and grid information (unrelated to energy)	O	O
J. Ability to be programmed with preferences and act on them (whether by user, remote agent, or both) ^c	M	O
<p>Key</p> <p>M: mandatory capability O: optional capability P: prohibited capability NA: not applicable</p> <p>^a Other categories of information include status of CEM or DEM. ^b DEMs may be designed (or programmed) to be sensitive to some or all of the non-emergency smart operating modes in Table 2. ^c Programming options could include a "no-preference" setting in which user and/or or remote agent settings are passed on without further delay or processing. ^d A DEM may however be capable of directly sensing the condition of the grid (e.g. through monitoring frequency and voltage) in order to determine whether preset trigger conditions are met, and modifying product operation accordingly. ^e With regard to its energy functionality, a DEM can bind to only one CEM.</p>		

5 Smart operating modes

5.1 Classification of smart operating modes

The main smart operating modes of which a smart device can be capable are summarised in Table 2. The modes are indicated as rows (numbered 0 to 8) and the time parameters are indicated as columns (A to D). For example, smart operating mode 3C is one in which the product reduces or constrains load at a future time.

The device performance standard applicable to each type of device should describe how each condition is to be met, with reference to the parameters described in 5.2.

For example, for a device capable of smart operating mode 3 (constrain or reduce load), the following should be described:

- the commands or trigger criteria required for the device to enter and exit a period of constrained or reduced load operation;

- the way in which the load reduction or constraint is measured (e.g. by reference to a fixed value, by reference to a floating value, as an absolute power limit or by suspension of energy-intensive functions);
- the conditions under which a command or request will be delayed or ignored (e.g. if received at specified stages in the operating cycle);
- any limitations of device function or performance resulting from smart operation (e.g. inability to complete a cycle that is already in progress, reduction in wash performance); and
- the applicability of a user over-ride or an automatic over-ride before or during smart operation.

The device performance standard applicable to each type of device should also describe how this information should be reported, for example via a standard form or forms.

Table 2 – Smart operating modes

	Smart operating mode	A. Enter mode immediately ^b	B. Exit mode immediately ^b	C. Enter mode at future time or under defined trigger criteria	D. Exit mode at future time or under defined trigger criteria
0	Device information transmission ^a	Yes	Yes	Yes	Yes
1	Emergency off	Yes	Yes	NA	Yes
2	Off/standby	Yes	Yes	Yes	Yes
3	Constrain or reduce load	Yes	Yes	Yes	Yes
4	Start or increase load	Yes	Yes	Yes	Yes
5	Defer cycle ^c	Yes – i.e. do not start cycle yet	Yes – i.e. start cycle now	Yes – start cycle then ^d	Yes – complete cycle by then ^d
6	Start or increase supply	Yes	Yes	Yes	Yes
7	No supply	Yes	NA	Yes	NA
8	Other (as defined by manufacturer)	?	?	?	?

^a The ability to transmit information to a CEM is an optional capability of a DEM (see row D in Table 1), so suppliers should indicate if the product is capable of this mode, and what category of information can be transmitted (e.g. product status and power profile of operating cycle).

^b Allowing time for necessary safety and other considerations.

^c May be expressed as sequence of off/standby and then request/increase load instructions.

^d If both operating modes are activated then the cycle shall be completed within a time window.

5.2 Smart operating modes for specific devices

5.2.1 General

This section is intended to guide standardisation bodies in addressing smart operation and performance in the device performance standards for the products for which they are responsible.

Standardisation bodies should develop their own criteria for defining, describing and testing smart operating modes in a way that is appropriate for the product. Subclauses 5.2.2 to 5.2.6 give examples of matters to be considered when doing so, and alternative approaches to resolving common issues. While many of the examples are based on household appliances, other product types are also used as examples to illustrate particular points.

It is recommended that standardisation bodies follow the reference framework in Clause 4, and any departures or modifications should be identified, described and justified.

5.2.2 Safety

User safety takes precedence at all times, including 'emergency off' requests. Controls incorporated in the appliance shall take priority over controls actuated by remote operation. Within the IEC, safety of household appliances is covered by the IEC 60335 series. Reference to safety issues in this document are not intended to conflict with those of the IEC 60335 series.

As standardisation bodies develop smart capabilities, they should be aware of any potential safety issues that may be caused by smart operation, and if not already covered by IEC 60335, they should bring them to the attention of the TC responsible for the IEC 60335 series.⁴

The following examples illustrate how smart operation could address safety issues:

- devices should be allowed to complete maintenance or safety modes (e.g. oil recovery cycle for air conditioners or cooling down phase of dryers), if they are in such a mode when they receive an initiating signal or achieve the trigger criteria for smart operation;
- some devices can need to operate cooling fans for some time after a main heating function ceases (e.g. tumble dryers);
- some devices can need to revert to user operation to avoid infringing performance criteria (e.g. storage temperatures in freezers and refrigerators);
- some devices can need time to allow for an orderly shutdown of other devices; for example, swimming pool pump controllers need to shut down chlorinators and pool water heaters which depend on a flow of water for their safe operation before shutting down filtration pumps.

5.2.3 Always available functions

The device should revert to user operation in the event of a fault in communications or in the CEM.

Devices should always be able to retain control settings and the capability to respond to changes in conditions or instructions, even in emergency off mode except in cases where the power has been lost by a hardware protection device or circuit. In some cases of constrained load operation, the user will benefit from continuing the operation of auxiliary equipment even if the primary energy service ceases. For example, a solar water heater where reduce or constrain load operation interrupts the booster element could still provide useful hot water if a circulation pump is permitted to keep operating to allow water to be drawn from the storage tank.

5.2.4 Initiation and termination of smart operation

Depending on which smart operating condition is being tested (see Table 2), the device should enter the required smart operating mode within a specified time after an initiating signal is received or trigger criteria are met, subject to any safety considerations (see 5.2.2).

Instructions for non-immediate operations may be expressed in terms of:

- time (e.g. time elapsed from signal, start time and termination time or start time and duration); or
- threshold trigger criteria (e.g. energy price, temperature); or
- a combination of these.

It is possible that a device will be switched off (or in standby mode) at the time the initiating signal is received or initiating condition is met. The response will depend on whether the initiating signal or condition is instantaneous or persistent. If persistent, then a device switched on by the user (or a timer) while the initiating signal or condition is still present should either not commence operation at all (for off/standby modes) or should enter the required smart operating mode within a prescribed time after starting.

⁴ At the time of publication, IEC TC 61 was responsible for the IEC 60335 series.

Each smart operating mode may have a time parameter, as indicated in Table 2. The description of smart operating modes in device performance standards will need to address how the device should respond under various combinations of requests (or commands) to enter smart operation, and the point in an operating cycle when these may be received.

As an example, it may be specified in the device performance standard that the device should respond according to the specific rules if it receives requests for smart load operation which:

- are instantaneous (i.e. have no time duration); or
- indicate a definite time duration; or
- indicate an indefinite time duration.

Annex B gives an example of device response rules depending on whether requests for smart operation combine logically to create a single-point request, which has no persistence or duration beyond the time it is received, a request with a known or controllable duration or a request of unknown or uncontrollable duration.

Device performance standards should specify if a fixed rule or set of rules are to apply and how the manufacturer should provide relevant information to the user (Clause 7).

5.2.5 Interaction with the CEM

If a smart device does not comply with instructions from the CEM within a given period (if such a period is specified), and the device is capable of two-way communications with the CEM, the device should inform the CEM of the reasons for non-compliance with the instruction.

NOTE: the mandatory capabilities listed in Table 1 can be achieved with one-way communications, so two-way communications are optional.

5.2.6 Smart devices in user operation

All smart devices should be capable of user operation if the DEM is inactive or removed.

All DEM-ready devices should be capable of user operation, whether or not a DEM is connected.

All smart devices should be capable of user operation, whether or not a CEM is connected.

When in user operation, all devices capable of smart operation should comply with the relevant device performance standards applying to non-smart devices of the same type (see Annex A for a list of performance standards applying to typical devices).

5.3 Operation in "constrain or reduce load" mode

5.3.1 General

In this mode, the device is still able to perform its primary function, but constrains or limits its electricity load. Operation in this mode may be described in a number of ways, such as (but not limited to):

- minimisation of load by avoiding or delaying energy-intensive processes that are ancillary to the primary function (e.g. delaying defrosting or ice-making, for refrigerators);
- reduction of load by x % (compared with a fixed or floating reference value);
- reduction of load by a specified value;
- reduction of load to no greater than a fixed value.

Reference values or constraint levels should be determined by the relevant standardisation bodies according to the characteristics of the specific device. The following examples (5.3.2 to 5.3.8) are for guidance only. Some approaches are more suited to constraints expressed in terms of peak power terms and other approaches are more suited to constraints expressed in energy terms.

5.3.2 Fixed reference value

The reference value may be the input electrical power of the device when operating at rated output (e.g. for an air conditioner tested at ISO heating condition H1) or some other value, preferably one that is determined during testing and declared by the manufacturer.

The maximum load for electrical wiring purposes is generally not a suitable reference value, because if the device is operating at a significantly lower load when constrained or reduced load operation commences, there may be no load reduction benefit. For devices where the maximum wiring load is very high (e.g. three-phase devices) it is preferable to specify reference values in other ways.

5.3.3 Floating reference value

The reference value may be the average power recorded (or energy consumed) over a given period prior to the receipt of an instruction or attainment of trigger conditions (e.g. the last 30 min or the last 5 min).

NOTE Electronic controls in devices can usually be designed to sample power levels at short intervals (e.g. every second) and maintain a moving record of average values.

5.3.4 Exclusion of specified functions

It is possible to specify energy-intensive processes or functions that do not need to be performed while the device is in constrained or reduced load operation (e.g. defrosting in refrigerators, or the use of electric resistance heating elements in hybrid heat pump water heaters).

The maximum length of time for which a function may be suspended, or the trigger criteria for ending such a period (e.g. the user opening a refrigerator door) may also be specified.

5.3.5 Multiple criteria

A constraint can be expressed as the satisfaction of several criteria at once, or the highest (or lowest) of a range of values. For example, "energy use during the period of constraint shall not exceed 50 % of the value that would have been achieved if the device had been operating at full load over the same period, or not more than 1 kW, whichever is higher (or lower)."

The multiple criteria approach is useful for devices where load during user operation may be highly variable (e.g. clothes washers, electric vehicle chargers).

5.3.6 Preset constraint levels

One or more fixed constraint levels may be preset into the device, the DEM or the CEM, e.g. 75 % and 50 % of the reference value. Load reduction requests may be expressed in relation to these fixed constraint levels (e.g. "reduce to the closest value to 50 % of reference value"), or as a maximum reduction (interpreted as "highest of the preset reduction values") or a minimum reduction (interpreted as "lowest of preset constraint levels").

5.3.7 Variable constraint levels

A variable constraint level is one that does not necessarily correspond to a preset level. For example, the instruction may be "reduce to 83 % of the reference value".

Variable constraints can be achieved in different ways. For a constraint expressed in energy terms, even if a device is only capable of on-off operation (e.g. a resistance element, or a single-speed motor), the device could still achieve any given constraint level by switching the element or motor on and off in sequence – e.g. 5 min off out of every 30 min will reduce the average load to 83 % of the reference value (which, in this case, is full load).

Different communications protocols express constrain or reduce load requests differently, so device performance standards should specify how various commands are to be translated to the constraint levels possible for that particular device.

5.3.8 Expressing constraints in power or energy terms

The target constraint level should be expressed in a way that can be tested. There is more than one way to specify this, for example:

- as an absolute power level that cannot be exceeded at any time during the period of constraint (e.g. 1,5 kW); or
- as permitted energy consumption over a specified period (e.g. 750 Wh per 30 min).

More than one constraint may be applied at the same time.

Expressing the constraint as maximum energy consumption over a specified time period gives manufacturers more design freedom, because a device may operate at close to maximum load for 10 min, for example, and at very low load for the remaining 20 min of a 30-min period. It is necessary to specify the time period over which energy consumption will be measured so that the device's control software can make the necessary calculations as soon as smart operation commences, and manage the device accordingly.

The compliance testing will have to be carried out over the same time period (or multiples of it, e.g. 60 min or 90 min in this example). This does not mean that periods of smart operation need always be exact multiples of 30 min – in practice they will almost certainly not be – but this approach offers a relatively simple and repeatable way to measure device operation under an energy constraint.

For devices with multiple phases, the limits should be specified on a per phase basis as well as a total sum value.

5.4 Operation in "start or increase load" mode

5.4.1 General

In this mode, the device commences operation even though direct user settings, thermostats or timers do not call for operation.

The aim of this response may be to:

- provide a rapid response load to the grid, so that energy is consumed when its price is low, or it may otherwise be wasted (e.g. when renewable generation sources may otherwise have to be disconnected or "dumped" in order to maintain grid stability); and
- act as part of a series of responses that together achieve a desired outcome e.g. time shifted operation.

5.4.2 Suitable devices

Devices are suitable for request or increase load response if they meet one or more of the following criteria:

- they deliver an energy service that needs to be delivered regularly but may not be strictly time dependent (e.g. swimming pool pumping);
- they embody a form of thermal storage, whether sensible or latent (e.g. water heaters, ice-makers); or
- they are SSESs, which can store electricity and later discharge it to the grid (e.g. batteries, both stationary and in electric vehicles).

Devices that could become dangerous if left unattended are not suitable for "request or increase load" response (see 5.2.1).

5.4.3 Protections and safety measures

Even if a device is capable of initiating or increasing load, it should not do so if any of the following conditions are present:

- the device-specific safety standard does not allow remote operation or control;
- the operation could result in an infringement of safety standards (e.g. through dangerous hot water temperatures or unexpected operation of equipment that may be in contact with the user);
- the device is unable to perform its primary function; or
- it would result in damage to the device (e.g. if a storage battery reaches a maximum safe energy storage level).

5.4.4 Devices already under load

Devices may already be operating at the time of receiving a request to start or increase load. If so, they could:

- ignore the request: i.e. continue their cycle or operation and cease operating when the user switches the device off or the cycle is complete;
- prolong operation (if consistent with the device's specified safety limitations and with its primary function) as long as the request lasts or until specified limits are reached (e.g. maximum safe storage temperatures in a water heater); or
- increase load if possible (e.g. if a battery is charging at a rate of 2 kW then it would increase the rate to 3 kW).

5.4.5 Risk of energy waste

The objective of increasing load may conflict with the objective of using energy efficiently in some circumstances. For example, heating or cooling a space by remotely switching on the heater or air conditioner, without information about current and intended occupancy and the thermal properties of the conditioned space, can result in energy waste if the space remains unoccupied. Remotely switching on a swimming pool pump would be of no energy value if it resulted in more pumping than necessary to keep the pool clean.

To minimise the risk of energy waste, there should be a high level of confidence that energy used during start or increase load operation is likely to displace future energy consumption, and/or avoid a future load peak. This needs to be determined according to the pattern of use of each device. For example, pumping run time during load request operation could be subtracted from the balance of pre-programmed run time over a given time period.

5.5 Operation in "defer cycle" mode

5.5.1 Smart deferment and user deferment

Smart deferment is a mode of operation in which the CEM and DEM have a role. A deferment where the user simply programs a delayed start using a device's normal controls is not smart deferment.

NOTE The ability for users to load a device such as a clothes washer, select a wash cycle but delay the start by a specified period (or to start at a selected clock time) is already a common feature in products. The response is unaffected by whether the user's motivation is related to electricity price or some other reason. The operation only becomes smart when it relies on a combination of grid and device information, so that the cycle takes place when electricity prices are low.

Defer cycle mode is relevant to devices that deliver their primary function in discrete cycles (e.g. wash cycles) rather than continuously (e.g. refrigerators).

NOTE A refrigerator can defer some of its ancillary operations such as icemaking or defrost, when operating in constrain or reduce load mode. This is different from defer cycle mode.

Defer cycle mode involves a set of operations that together meet defined objectives (or 'use cases'). For example, the user wants to have a clothes wash cycle completed by a specified time (e.g. 10 pm) and also wants to minimise the running cost⁵.

5.5.2 Information required for this mode

Operation in this mode may require information about electricity prices or other determining parameters that will apply over the time window allowed for the required operation, so that these can be overlaid with the device's projected cycle duration and energy profile.

This information may be based on data held in memory or information obtained from external sources.

5.6 Operation in "start or increase supply" mode

5.6.1 General

This mode of operation is only available for SSESs that generate or store electricity. In this mode, the SSES commences supply of energy to the grid even though user settings do not call for supply to the grid, or increases supply if already supplying.

5.6.2 Suitable products and devices

The following SSESs are suitable for operation in this mode:

- storage batteries (when in a sufficiently charged condition);
- electric vehicle charge/discharge controllers (when a sufficiently charged EV is connected);
- distributed generation devices that can be switched on (e.g. fuel-using generation sets, when there is sufficient fuel);
- distributed cogeneration devices, where the balance between heat and power production can be changed.

5.6.3 Protections and safety measures

Even if an SSES is suitable for and capable of responding to a request for supply, it should not respond, or cease responding, if any of the following conditions are present:

- the operation would infringe a safety standard (e.g. through energising a part of the network that has been de-energised for maintenance);
- there is a local network capacity constraint;
- it would result in damage to the SSES (e.g. if a storage battery reaches a minimum safe energy storage level); or
- there is an unacceptable loss of utility to the user (e.g. an electric vehicle that is so discharged that there is no time to recharge it before the user needs to drive it on the next day). The presence of a condition such as this would need to be determined by analysis of user settings and preferences, to the extent that these are programmed by the user or learned by monitoring user behaviour.

⁵ See also use cases in IEC TR 62746-2.

5.6.4 SSESs already supplying energy

SSESs capable of responding to a request to start or increase supply may already be supplying energy to the grid at the time of receiving such a request. In some cases (e.g. renewable generators), the rate of supply cannot be controlled, so the appropriate response is to maintain supply at the same settings (in this case, to the extent of available energy).

Where an SSES that is able to vary the rate of supply is already supplying energy when it receives a request to start or increase supply, it could either:

- ignore the request: i.e. continue to supply at the same rate until the stored electricity is fully discharged, the generation fuel is exhausted, or the device ceases operating when the user switches it off;
- increase the rate of supply if possible – e.g. if a battery is discharging at a rate of 2 kW, then increases this to 3 kW. As a request to enter this operating mode is likely to come at a time when the grid has excess load, any supply increase is likely to be valuable.

5.7 Operation in "no supply" mode

In this operating mode, an SSES may not supply energy to the grid even though user (or timer) settings call for supply. It is intended to:

- act as a safety measure, e.g. in parts of a network that have been de-energised for maintenance or due to accidental damage;
- help manage voltage within stability limits, e.g. to avoid problems that can occur in areas with a high concentration of renewable generators (typically rooftop PVs, when solar availability is high but local electricity demand is low).

This mode of operation is likely to be initiated via direct load control by a remote agent, and if so it should be given at least the same level of priority as an emergency off command.

No-supply operation may also be initiated by the DEM or the CEM, for example if the current buyback electricity price offered by the grid is lower than the value of using or storing the energy locally. It may be accompanied by the CEM initiating start or increase load operation for other devices under the CEM's control.

5.8 Overrides

One or more types of overrides may be built into CEMs, DEMs or DEM-ready devices:

- user override, intended to enable users to return the device to user operation despite the CEM or DEM initiating smart operation, because the user's immediate preference differs from any pre-programmed preference; and
- automatic override, intended to return the device to user operation after a possible malfunction in the CEM or DEM, or conflicting instructions from a remote agent.

Not all devices need all types of override, and even if they are present, there can be circumstances under which the user consents to having them disabled.

The presence of an override that can be enabled or disabled remotely, or via the user entering a code supplied by the remote agent, can reduce the risks to both parties by allowing different forms of override setup without having to replace the device.

EXAMPLE A user may wish to enter into a direct load control contract that offers very low energy prices in return for disabling the user override. The presence of an override that cannot be disabled would exclude the user from entering into this contract. In this example (which is common for electric water heaters on special controlled tariffs), users are still sovereign because they are free to enter into such arrangements if they consider that the advantages outweigh the risks, and can withdraw from such contracts in the event that they change their mind (subject to any notice period in the contract).

5.9 Device information transmission

Device performance standards should address whether and how the device should inform the CEM about smart operation status or other operating information, such as actual power consumption in user operation.

5.10 Status Indicators

Device performance standards should address whether, and if so, how, the device should indicate to users that it is in a smart operating mode.

Status indicators can work in various ways: e.g. they can alert users to smart operation events they may not otherwise have noticed, and so increase user override rates. At the same time, if users notice a change in device operation, then an indicator can give reassurance that the device is not malfunctioning, and could save unnecessary calls to manufacturers and utility companies.

Indicators may be on the device itself (e.g. an indicator light), a message on the control panel or remote control, or a message on an in-home display or smartphone.

Consideration should be given to the needs of users of different physical abilities: e.g. the provision of audible as well as visible indicators.

6 Testing smart operating modes

6.1 General principles

It is widely recognised that smart devices by their nature are capable of flexible response to changing conditions, and that is impractical (if not impossible) to devise and undertake tests that verify performance under all possible conditions.

Nevertheless, all smart capabilities and operating modes should be defined by the manufacturer in a way that allows testing of the device.

Device performance standards that cover smart operating conditions should also address the possibility that a manufacturer may offer to the market a device with capabilities that they wish to describe as "smart", but that are additional to those already defined. The classification in Table 2 allows for this (i.e. operating mode 8). If these are to be permitted under the relevant device-performance standard, the manufacturer should describe the conditions under which the operating mode can be tested.

All tests, including those suggested by manufacturers, should be designed to prevent the possibility of circumvention.

EXAMPLE It is more difficult to build in 'circumvention' routines that sense that the device is under test and make it perform in a way that it would not perform in actual use, if the test allows ranges of operating conditions, e.g.:

- "The device shall be operated in this mode for between 20 min and 60 min"; or
- "For this test the wash temperature shall be adjusted between 40 °C and 60 °C"; or
- "This test may be performed under any one of economy, normal or intensive settings".

The tester should record which value was chosen to assist repeat testing. If enough values are subject to condition ranges, then as test results accumulate over time, combinations in which the device fails to perform can be identified.

It is also important for the manufacturer to be clear about whether a device is capable of smart operation in all operating modes, e.g.:

- for an air conditioner, when in heating mode, in cooling mode and in climate control mode (in which both heating and cooling are possible in order to maintain a target temperature); or

- for an EV charger, when charging or discharging (if the device is capable of managing discharging) or when doing neither actively (i.e. on standby).

If additional equipment is required to test the smart capabilities and operating modes of the device (e.g. an external DEM or CEM or some other optional part), this equipment should be clearly specified by the relevant standardisation body or by the manufacturer.

Where device-performance standards specify procedures for testing the smart operating modes, the relevant standardisation body, or the manufacturer, may indicate restrictions on testing procedures to avoid potential conflicts in device operation, or may indicate how the device will respond in the event of conflicts or incomplete information.

Restrictions may include (but are not limited to) the following examples:

- certain instructions or commands should only be sent to the device at certain points in an operating cycle (e.g. "smart operating mode 2A should not be tested during a wash cycle");
- if a CEM sends a request that would be acted on during a part of an operating cycle where a response is likely to lead to higher energy use (e.g. reheating water to compensate for cooling due to an interruption), the DEM does not need to respond to the request.

6.2 Setup for tests

Ideally, the testing of smart operating modes should be conducted under the same conditions as the testing of performance under user operation – in a similar climate-controlled room, for example. Therefore, the relevant standardisation body may wish to specify that tests for smart operation should be conducted at the same time, or immediately after, performance tests under user operation, such as those that may be required to determine energy consumption.

It may be necessary to allow a period between test sequences for the device to cool down or return to a neutral condition in some other way.

The setup instructions for the tests should specify all the elements, components and instrumentation required to achieve and measure the modes of operation being tested. Depending on the device, this may include:

- a DEM that matches the manufacturer's specification, if not incorporated into the device;
- a CEM that matches the manufacturer's specification, if not incorporated into the device, setup to interact with the DEM in the required manner (e.g. wireless, cable, powerline carrier etc.);
- for testing direct load control operation, a means of replicating the instructions and commands from a remote agent, and communicating them to the device in accordance with manufacturer's instructions;
- for testing smart operation, a means of achieving the trigger conditions specified by the manufacturer;
- a test load where relevant (e.g. for clothes washers or dishwashers); test loads should comply with the load specified in the performance standards for that device, in their size and composition;
- the installation of the device; if the device needs to be connected to water as well as power, the mode of connection (e.g. to hot water supply only, cold water supply only, or both) and any special provisions required for draw-off and discharge of water (e.g. straight to drain, or to be measured and weighed, etc.);
- if the device controls other equipment (e.g. an EV charger with an EV, or a pump controller with a pump), in many cases an equivalent load can be used for testing; For example, an EV charger can be tested with a device that simulates the electrical characteristics of an EV, rather than an actual vehicle;
- voltage and frequency limits for testing;

- accuracy of instrumentation and frequency of readings.

Simplified tests can also be useful for screening purposes (e.g. to test whether smart capabilities are present, but without determining actual performance in smart operating modes)⁶.

6.3 Determining compliance with standards for smart performance

The test procedure should clearly specify all steps in the testing process. If a choice within a range of values is permitted in the procedure (e.g. with regard to the selection of test conditions within a range of given parameters), the values selected should be recorded. Where tolerances are permitted (e.g. in response times or in the target load value calculated as a percentage reduction from a reference value), the tolerance limit should be specified – e.g. the device is deemed to comply if no test value exceeds a target value by more than 5 %.

The tolerances should be appropriate to the type of device⁷. Rounding of values should be specified (e.g. number of decimal places, or number of significant figures)⁸.

The conditions that trigger a compliance failure should be specified, e.g.:

- if the device, while operating, fails to enter the smart operating mode of which it is claimed to be capable within the specified response time;
- if the device, when switched off and on again during smart operation, fails to resume that operating mode within a specified time;
- if the device does not operate in accordance with the requirements of the smart operating mode; or
- if the information on smart operation provided by the manufacturer is incorrect.

6.4 Determining the impact of smart operation on device performance

The performance of a device with regard to its primary function can be impacted by smart operation. The extent of this impact will be influenced by the particular smart operating mode, and – for devices that operate in discrete cycles rather than continuously – the point in the cycle when smart operation applies.

The presence of a DEM or CEM may also influence standby power consumption.

It is impractical to test the impact of smart operation on all programmes and operating conditions, so the device performance standard should nominate the program or programs to be used. These would usually be the same programs as used for the measurement of energy consumption.

An initial calibration test under user operation should be carried out. While the conditions should be identical to the existing performance test, it may be necessary to specify additional instrumentation, observations or measurements to collect the necessary information for later comparison: for example, the sequence, duration, average power consumption and peak electrical power for each separate operation (e.g. heating, washing, rinsing, spinning, etc.).

The test should be repeated with various smart operating modes applied at different points in the program, after which the program should be allowed to run to completion.

⁶ See for example Annex P of IEC 60456:2010.

⁷ See for example IEC TR 62617.

⁸ Refer to ISO 80000-1.

The same parameters should then be measured as under the initial calibration test. Depending on the device, these parameters may include:

- electricity consumed between commencement and completion of the operating program;
- other forms of energy and/or water consumed between commencement and completion of the operating program;
- maximum and average power level attained during each operation;
- maximum and average noise level attained during each operation;
- the performance, e.g. programme time, cleaning performance, rinsing performance, temperature during operation, and others.

Any change in these parameters between user operation (as recorded in the calibration test) and smart operation can then be measured and reported.

7 Information to be provided by manufacturers

7.1 General

The relevant standardisation body should consider whether, and if so, how, to define the information that should be conveyed about the smart capabilities of devices.

This places an obligation on manufacturers to be clear in their description of a device's smart capabilities to:

- potential buyers, who may rely on the descriptions of smart capabilities before purchase;
- device installers, who may need to adjust device settings or connect external CEMs;
- third parties such as utility companies or remote agents, who may wish to offer financial incentives to users who purchase devices with specific smart capabilities; and
- policy-makers and regulators, who may wish to regulate that all devices sold in their area of jurisdiction must have specific smart capabilities.

7.2 Information that could be provided

7.2.1 Technical information in device-performance standards

Device-performance standards should list the information to be reported by manufacturers when describing a device's characteristics, smart capabilities and operating modes.

The information can include (but is not limited to) the following:

- the main operations that comprise a performance cycle (e.g. pre-wash, main wash, rinse and dry for cleaning products);
- whether an operation can be modified (to reduce or increase power) or interrupted at any time on request;
- whether it can only be modified or deferred if it has not yet commenced at the time of a request; or
- whether it cannot be modified, interrupted or deferred.

For operations that can be modified to reduce or constrain electrical load, the manufacturer should indicate whether the amount of reduction is:

- determined solely by the device, irrespective of CEM requests; or
- whether different levels of reduction can be achieved on request from the CEM.

7.2.2 Information for device users

In addition to the information that would otherwise be disclosed about the device and its performance, the manufacturer should state:

- the smart operating modes of which the device is capable (referring to Table 1);
- the smart operating modes which are set as defaults (if any);
- whether the capability for each smart operating mode can be activated or deactivated by the user and, if so, how;
- whether the capability for each smart operating mode can be activated or deactivated by the installer and, if so, how;
- the impact of smart operation on the performance of the device; and
- any circumstances and combinations of settings where smart operation cannot be achieved.

This information should be accessible to potential users prior to purchase⁹.

7.2.3 Information for appliance installers

The manufacturer should provide information on:

- how to install the smart device;
- how to activate and deactivate the capabilities for smart operation of the device;
- the type of DEMs and CEMs with which the device is interoperable (if applicable, i.e. the DEM and/or CEM are external).

⁹ See ISO/IEC Guide 14:2003.

Annex A
(informative)

Device performance standards for typical devices

Table A.1 shows a selection of existing device performance standards for which smart capabilities and smart operating modes consistent with this document could be developed (as amendments or as new parts), subject to the decisions of the relevant standardisation bodies, technical committees and/or subcommittees.

Table A.1 – Devices within scope of IEC TC59 and its sub-committees

Ovens	IEC 60350
Microwave ovens	IEC 60705
Ventilation hoods	IEC 61591 IEC/TS 61902
Washing machines	IEC 60456
Washer and dryers	IEC 62512
Refrigerators	IEC 62552
Tumble dryers	IEC 61121
Dishwashers	IEC 60436
Standby	IEC 62301

Annex B (informative)

Example of response rules for smart operating modes

If Annex B is included in a standard, it would be normative text and "shall" and "should" would be appropriate.

Table B.1 –Combinations of smart operating modes, timing and duration

Request or remote agent instruction ^a	Duration
A. Enter mode immediately (request) ^b	No duration
A. Enter mode immediately (instruction) ^c	Definite (It is remote agent's responsibility to terminate instruction or issue exit instruction)
B. Exit mode immediately (request)	No duration
C. Enter mode at future time or under specified trigger conditions (request)	No duration
D. Exit mode at future time or under specified trigger conditions (request)	No duration
A (enter mode now) + D (exit at future time) ^d	Definite
A (enter modes now) + D (exit when trigger conditions achieved)	Indefinite (ie trigger conditions may never be achieved so mode may never exit)
C (enter mode at future time) + D (exit mode at future time) ^e	Definite
C (enter mode when trigger conditions achieved) + D (exit mode at future time) ^d	Definite (whether entry trigger conditions will be met not is known, but exit is definite)
C. (trigger) + D (trigger)	Indefinite (even if entry conditions met, exit conditions may never be met).
C (time) + D (trigger)	Indefinite (exit conditions may never be met)
^a Refer to column headings of Table 2 for meaning of A, B, C and D. ^b A request leaves it to the CEM to comply. ^c An instruction is passed through from a remote agent to the CEM as a command. ^d If trigger criterion is "when tariff changes" and tariff change time is pre-programmed, that constitutes a specified time. ^e Time may be clock time or a set period after time that mode is entered.	

Table B.1 gives examples of how a device can be programmed to interpret requests for smart operation received at different points in the operating cycle. If a device is in operation at the time of receiving a no-duration request, then it shall respond immediately if it is in an operation that may be modified or interrupted. If not in such an operation, it shall continue until reaching the next interruptible or modifiable operation, then enter the requested smart operating mode. If there are no further interruptible or modifiable operations it may complete the program.

If a device does respond, it shall continue to hold that response until:

- completion of program (which is possible under constrain or reduce mode operation); or
- it receives an "exit mode immediately" request; or
- it receives a "future termination time" request, thus making the request of definite duration; or
- a user override (if present) is activated; or
- an automatic override (if present) is activated.

If a device is not in operation at the time of receiving a no-duration request, it shall take no action and shall not modify any subsequent operation.

For requests of definite duration:

- the device shall be capable of receiving and retaining the instructions whether or not it is operating at the time;
- a device that is in operation at the commencement of the period shall respond as if to a no-duration request (see above);
- a device that is programmed to start during the period shall defer its start until the end of the period (or later);
- if the user seeks to manually start the device during a period of definite duration, and the device has status indicators, it shall indicate that a smart operating mode has been requested (e.g. by displaying "no operation requested" or "low-power mode requested") and when the period ends (e.g. "until 6pm"). If the user does not override a "no-operation" request then the device shall defer its start until the end of the period (or later). If the user does not override a "constrain or reduce load request", then the program may commence but should be carried out in that mode;
- if the user again seeks to manually start the device during the period, then the same options are offered as above.

For requests of indefinite duration:

- the device shall be capable of receiving and retaining the instructions whether or not it is operating at the time;
- a device that is in operation at the commencement of the indefinite period shall respond as if to a no-duration request (see above) for one program only, and then revert to user operation;
- a device that is programmed to start during the indefinite period shall respond as if to a no-duration request (see above) for one program only, and then revert to user operation;
- if the user seeks to manually start the device during a period of definite duration, and the device has status indicators, it shall indicate that a smart operating mode has been requested (e.g. by displaying "no operation requested" or "low-power mode requested") and when the period ends (e.g. "until 6pm"). If the user does not override a "no-operation" request, then the device shall defer its start until the end of the period (or later). If the user does not override a "constrain or reduce load request", then the program may commence but should be carried out in that mode.

Bibliography

IEC 60335-1, *Household and similar electrical appliances – Safety – Part 1: General requirements*

IEC 60456:2010, *Clothes washing machines for household use – Methods for measuring the performance*

IEC 62394, *Service diagnostic interface for consumer electronic products and networks – Implementation for Echonet*

IEC TR 62617, *Home laundry appliances – Uncertainty reporting of measurements*

IEC TR 62746-2, *Systems interface between customer energy management system and the power management system – Part 2: Use cases and requirements*

ISO/IEC Guide 14:2003, *Purchase information on goods and services intended for consumers*

ISO/IEC 14543-4-3, *Information technology – Home Electronic Systems (HES) architecture – Part 4-3: Application layer interface to lower communications layer for network enhanced control devices of HES Class 1*

ISO/IEC 15067-3:2012, *Information technology – Home electronic system (HES) application model – Part 3: Model of a demand-response energy management system for HES*

ISO 80000-1, *Quantities and units – Part 1: General*

AS/NZS 4755.1, *Framework for demand response capabilities and requirements for demand response enabling devices (DREDS)*

AS/NZS 4755.3.1, *Interaction of demand response enabling devices and electrical products – Operational instructions and connections for air conditioners*

AS/NZS 4755.3.2, *Interaction of demand response enabling devices and electrical products – Operational instructions and connections for devices controlling swimming pool pump-units*

AS/NZS 4755.3.3, *Interaction of demand response enabling devices and electrical products – Operational instructions and connections for electric and electric-boosted water heaters*

AS/NZS 4755.3.5, *Interaction of demand response enabling devices and electrical products – Operational instructions and connections for grid-connected electrical energy storage (EES) systems*

ECHONET Consortium, <https://echonet.jp/english/>

prEN 50491-12 (TC205 WG18), *Use cases and requirements*

prEN 50631 (CENELEC TC59xWG7), *Household appliances network and grid connectivity*

US Environment Protection Authority ENERGY STAR Program Requirements, *Product Specification for Clothes Dryers (includes Connected Product Criteria)*, available at <http://www.energystar.gov/sites/default/files/specs//ENERGY%20STAR%20Final%20Version%201%200%20Clothes%20Dryers%20Program%20Requirements.pdf>

US Environment Protection Authority ENERGY STAR Program Requirements, *Product Specification for Residential Refrigerators and Freezers*, Version 5.0, available at <http://www.energystar.gov/sites/default/files/specs//private/ENERGY%20STAR%20Final%20Version%205.0%20Residential%20Refrigerators%20and%20Freezers%20Program%20Requirements.pdf>

INTERNATIONAL
ELECTROTECHNICAL
COMMISSION

3, rue de Varembé
PO Box 131
CH-1211 Geneva 20
Switzerland

Tel: + 41 22 919 02 11
Fax: + 41 22 919 03 00
info@iec.ch
www.iec.ch